

POWER OUTLET SYSTEM

DESCRIPTION

The power outlet system is designed to supply power for car accessories.

- The total capacity of the vehicle power outlet system is 12 V/120 W.
- This system is standard equipment on all models.
- This system is control by the Power Outlet ECU.

SYSTEM DIAGRAM

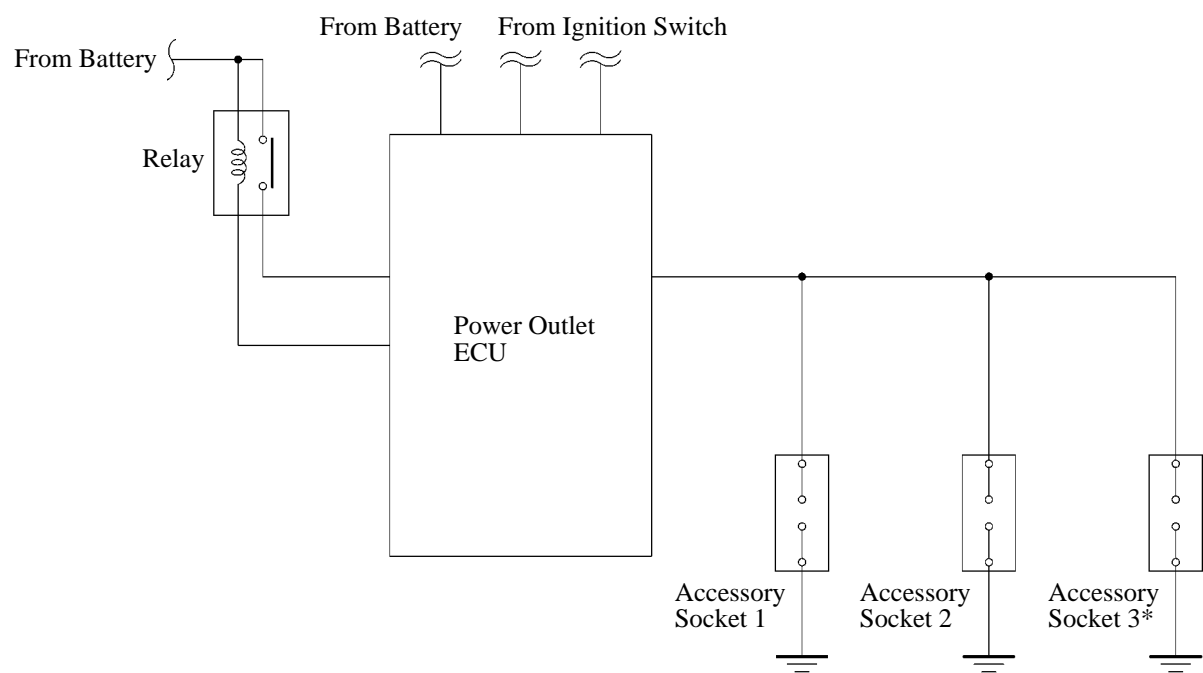

04E0BE44C

*: Double Cab Only

■ LAYOUT OF MAIN COMPONENTS

1. Bench Seat

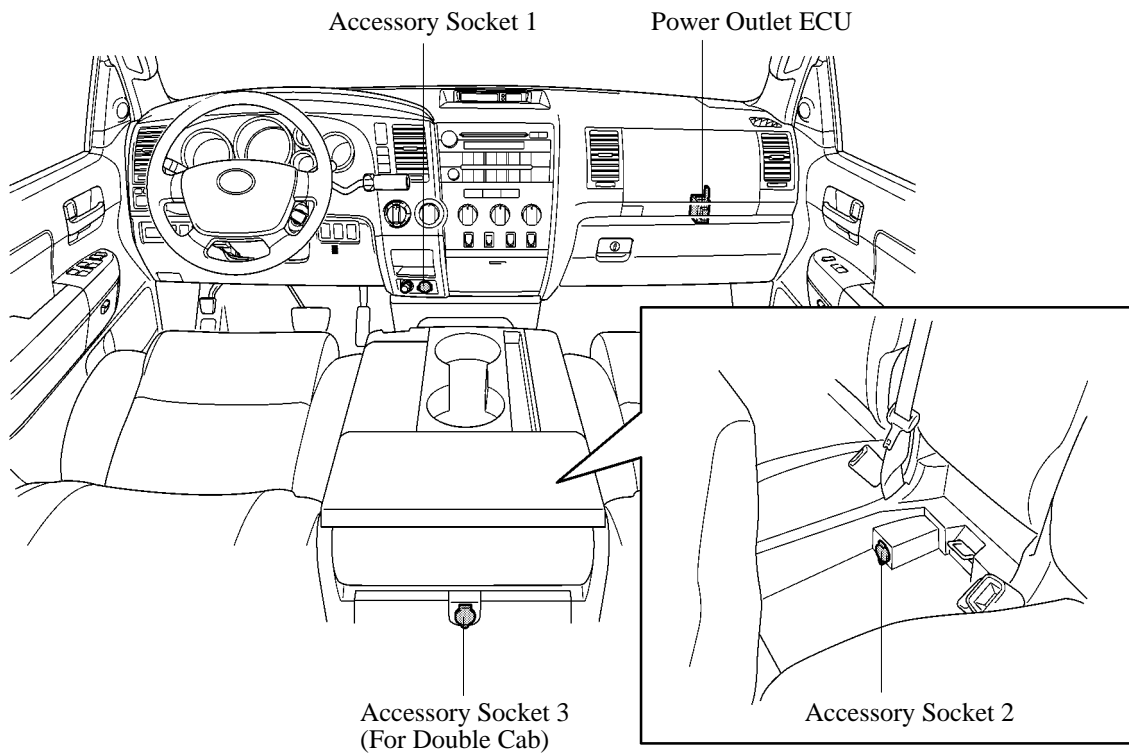

04E0BE34Z

2. Separate Seat

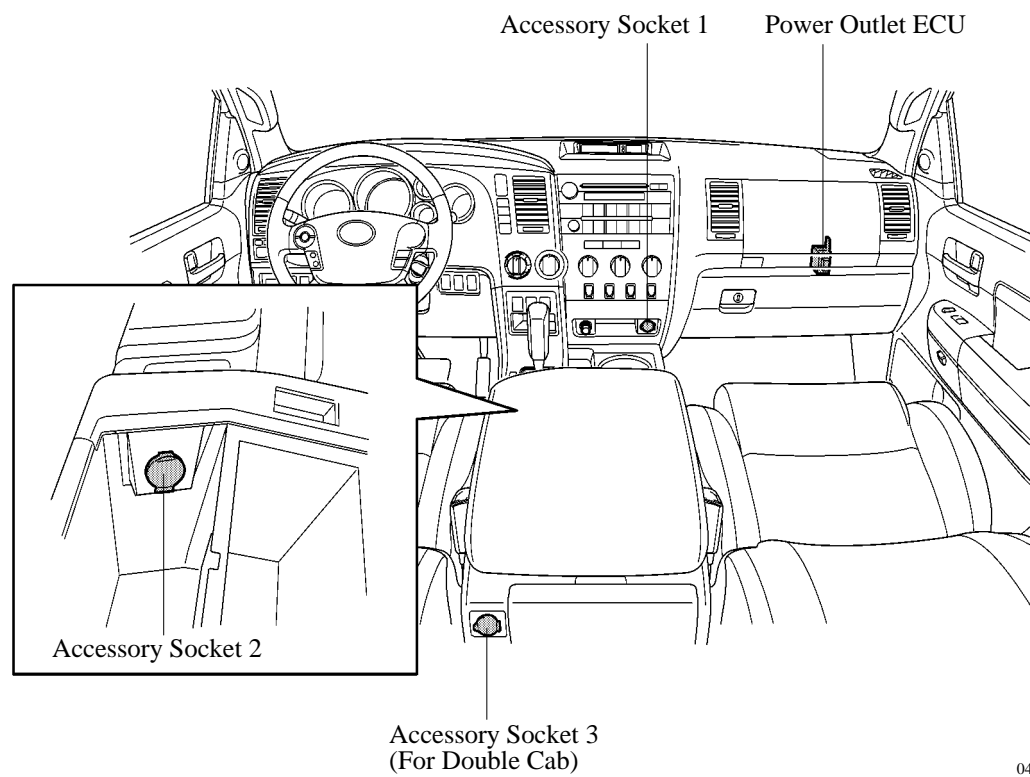

04E0BE35Z

■ SYSTEM CONTROL

The power outlet system controls its power source in accordance with the ignition switch position.

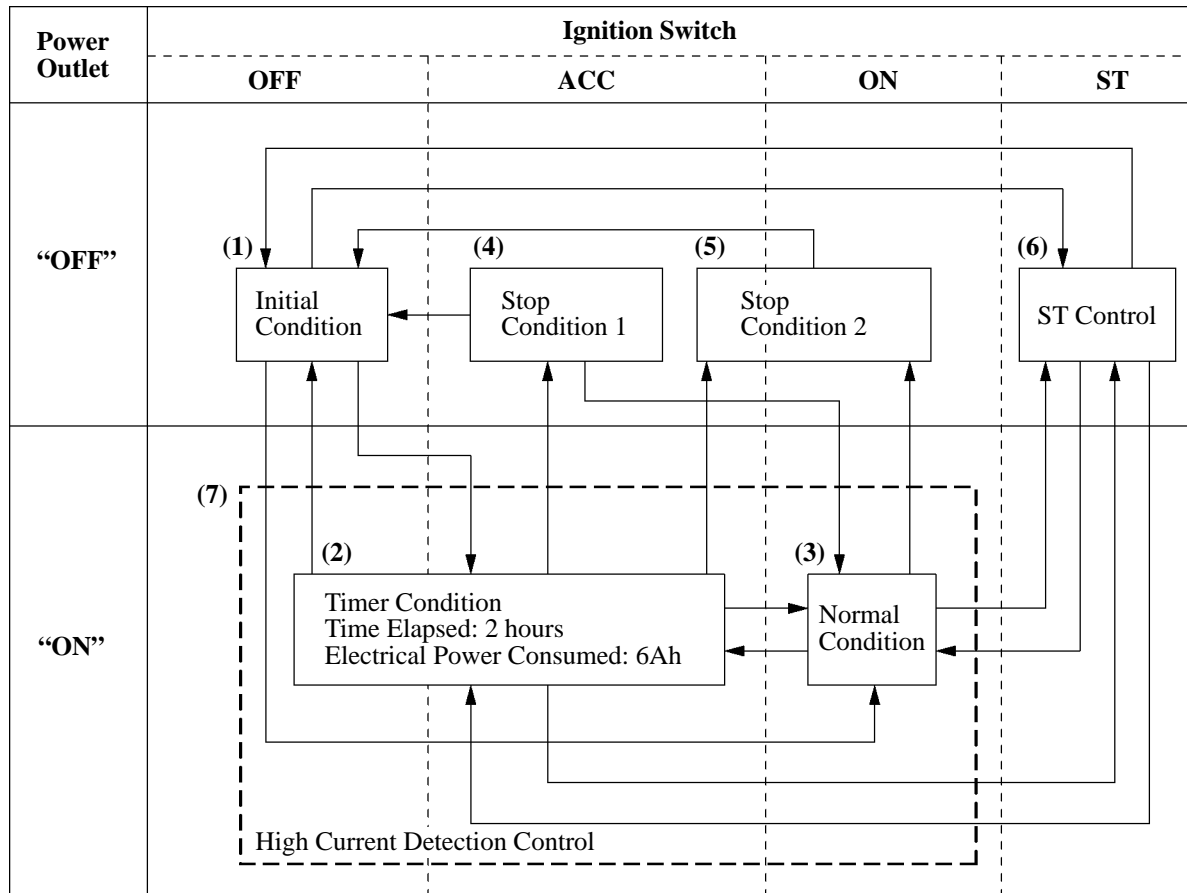

04E0BE115C

Condition/Control		Power Outlet	Outline
(1)	Initial Condition	OFF	Power Outlet ECU power off condition
(2)	Timer Control Condition	ON	The power outlet system starts this control when the ignition switch is in the ACC position. The Power Outlet System also starts counting the elapsed time and the electric current consumption. In case of any of these counters get bigger than the number in the specified table, the status will change to (1) or (4).
(3)	Normal Control Condition	ON	Provides power to the power outlets
(4)	Stop Condition 1	OFF	The Power Outlet ECU turns off the ACC relay and stops providing power for the outlets after timer finishes or after the electrical power consumed exceeds the limit.
(5)	Stop Condition 2	OFF	The Power Outlet ECU turns off the ACC relay and stops providing power for power outlet after excessive current flow is detected.
(6)	ST Control Condition	OFF	When the starter is ON, the Power Outlet ECU turns off the ACC relay and stops providing power for the power outlets to reduce the load on the battery.
(7)	High Current Detection Control	-	When condition is (2) and (3), the Power Outlet ECU detects current being consumed at the power outlets and judges if current flow is excessive.